

# COMBI-FLOW

MASS FLOW AND PRESSURE MEASUREMENT AND CONTROL



ULTRACLEAN  
METAL SEALED  
ELECTROPOLISHED  
ORBITALLY WELDED  
CLEANROOM ASSEMBLED

**BRONKHORST**  
**HI-TEC**

# BRONKHORST HIGH-TECH B.V.

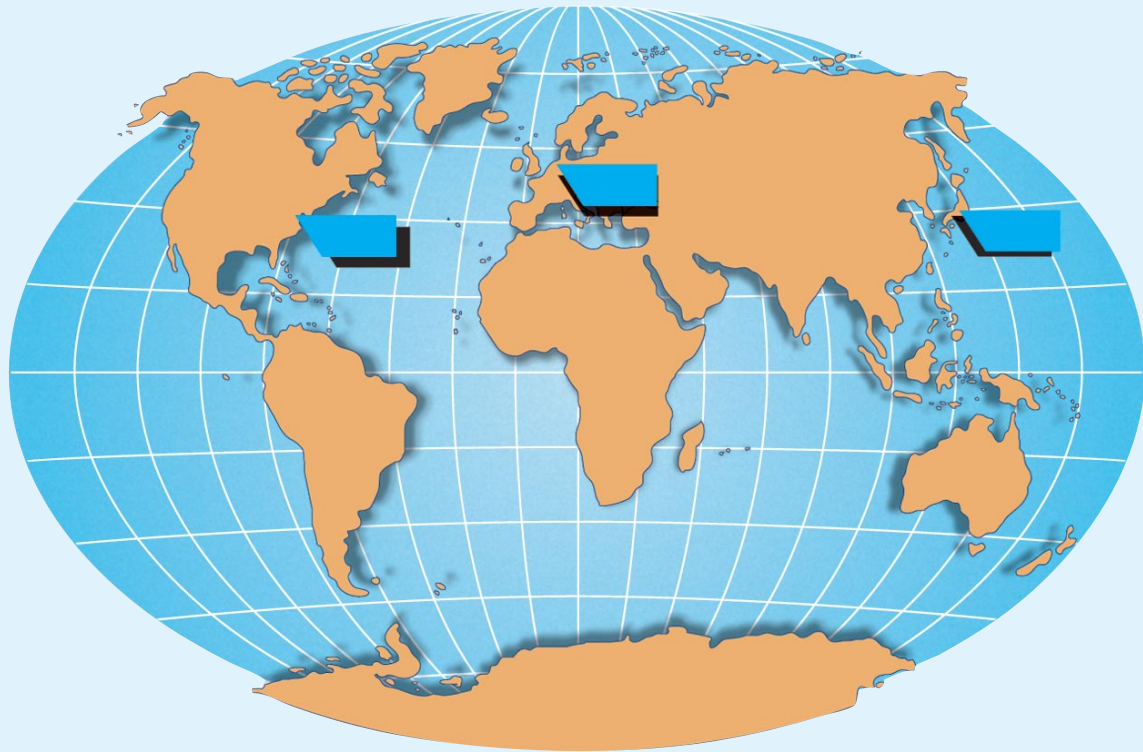

PRODUCTION AND SERVICE IN EUROPE, NORTH AMERICA AND ASIA

■ The company was formed in 1981 and has been established at Ruurlo, Netherlands since 1983. Today it offers the broadest range of thermal mass flow equipment in the world.

There are instruments for laboratory applications, general industrial use and ex-proof installations. Satisfied customers, state-of-the-art innovations and a high product quality have always been the corner stones of the success of Bronkhorst High-Tech. In 1987 the company was awarded the prestigious "King-William I" award for young, successful enterprises. In 1992 it qualified for ISO 9001 certification and in 1995 the company was certified ISO 14001 for meeting the international standards for environmental management.

Bronkhorst High-Tech signed agreements with Porter Instrument Company, USA and with Oval Techno Corporation, Japan, in order to ensure that similar products are manufactured close to the users. Also service and repairs are available from these locations.

The sales and service organisation in Europe is shown in the right hand page. The number of service stations is expanding rapidly. Furthermore Bronkhorst High-Tech is represented in the following overseas countries: Australia, New Zealand, Israel, India, South-Africa, Korea and Brazil.

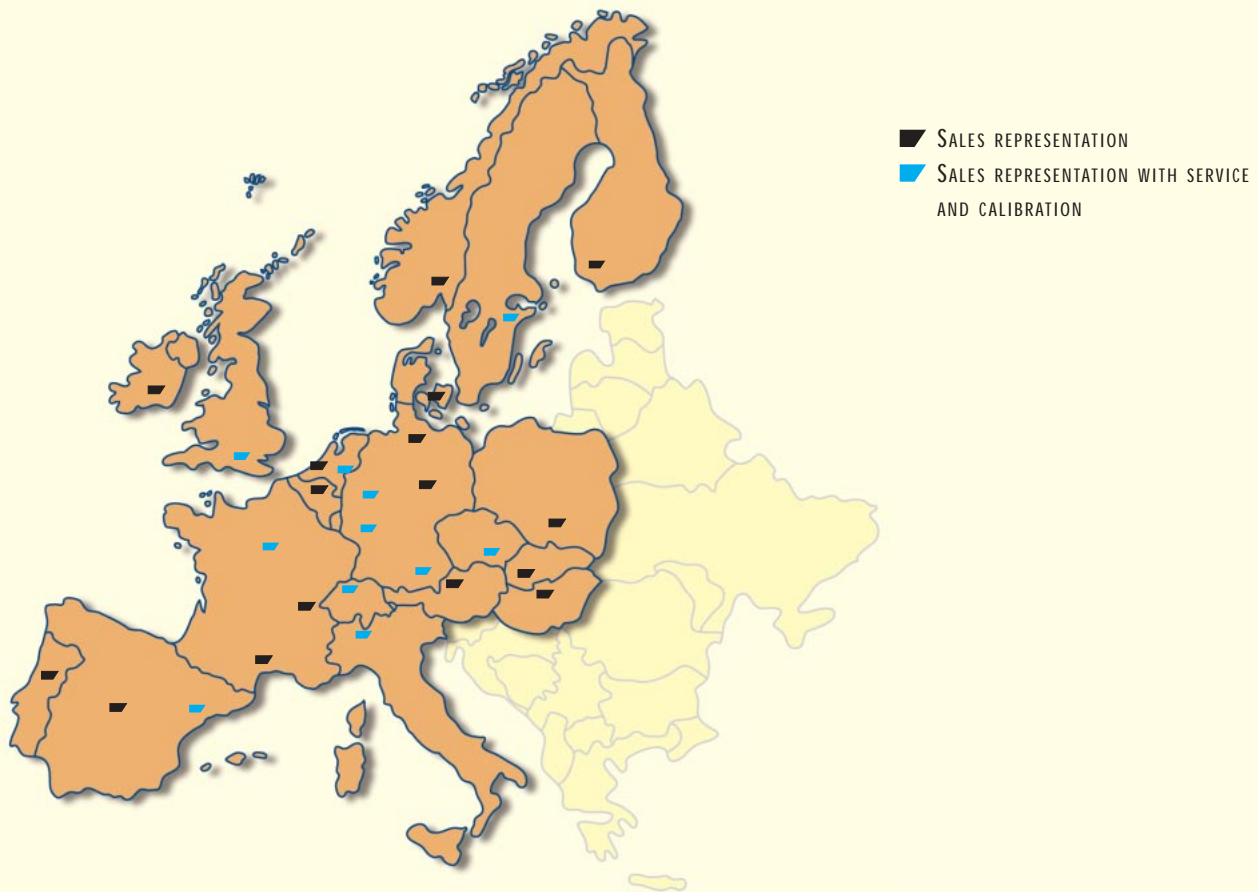

This brochure describes the instruments of the COMBI-FLOW series. These thermal Mass Flow Meters and Controllers have a unique construction with only one metal-to-metal seal with excellent resealing capability per module. Apart from mass flow control, additional functions such as fine-filtering, shut-off valve and pressure control can be integrated. Bronkhorst Hi-Tec products for other applications can be found on page 13 of this brochure.

CONTENTS	PAGE
Objective, approach and result	4
Features	5
Functional modules / dimensions	6
Specifications	10
Model number identification	12
Other Bronkhorst Hi-Tec products	13

# OBJECTIVE, APPROACH AND RESULT

## OBJECTIVE

The Bronkhorst Hi-Tec objective is to offer to the advanced semicon market the best system to realise mass flow and pressure control, together with associated functions such as fine-filtering and shut-off.

- Quality
- Reliability
- Stability
- Surface finish
- Leak tightness

## APPROACH

Making modifications to existing designs, as done by our competitors, such as replacing elastomer o-rings by metal o-rings etc, would surely not have led to the optimum result. Therefore the COMBI-FLOW line has been designed. Mass flow and pressure control functions, combined with filtering and shut-off functions as so often required, in a unique new style of modular arrangement.

## RESULT

- Minimum number of seals
- All metal-to-metal seals
- Excellent resealing capability

The base-blocks, either orbitally welded or coupled by means of male/female face couplings, are identical (except that of the pneumatic on/off valve) thereby leaving the choice which order of functions is best for your application. For instance, if you judge pressure buffering is an asset, then you start with a control valve module. In addition to the flexibility of the arrangement it is unsurpassed with regard to:

- Compactness
- Minimum dead volume
- Service friendliness

In case of service or repair the pipeline need not be interrupted; the modules can be removed by loosening one nut and be fully replaced without any adjustment!



## WELDED INTERCONNECTION

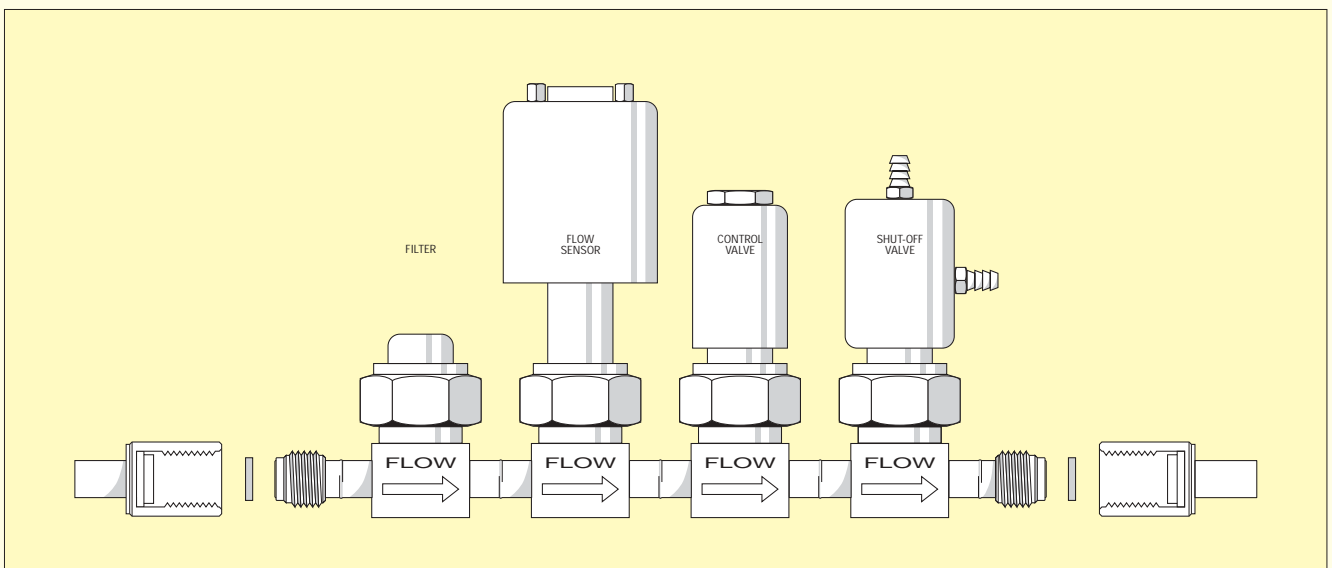

# FEATURES

It is self-evident that the COMBI-FLOW line has been engineered with attention to detail, and that the **mass flow meter module offers** features such as:

- Voltage regulation
- Temperature compensation
- Electro-chemically polished surfaces
- Mounting attitude insensitivity
- Reduced dead volume
- Vibration insensitivity
- Metal-to-metal seals
- Super stable sensor

**The patented sensor of innovative thin-film design does not need an auxiliary auto-zero circuit; it is and will remain stable!**

The combination of patented sensor with true laminar flow through both sensor tube and by-pass gives the COMBI-FLOW clear advantages:

## LAMINAR FLOW ELEMENT

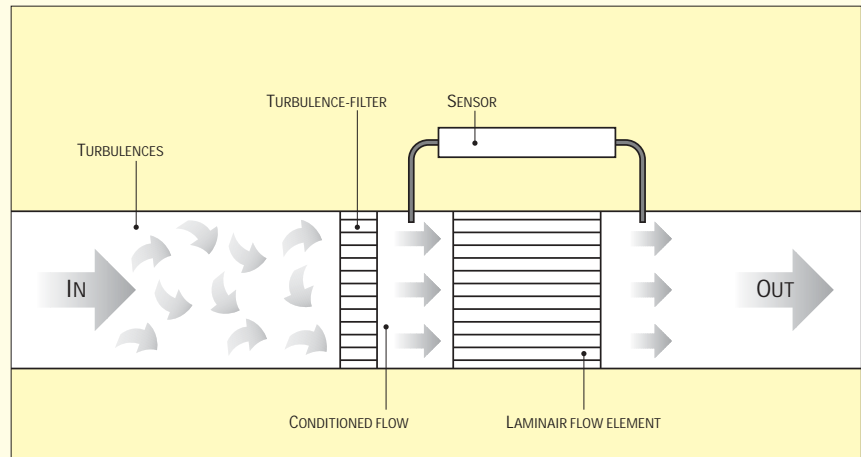

- **The optimum linearity**, which means there is only one (1) potentiometer for linearisation, where our competitors need several.

- **The perfect split between sensor - and by-pass flow**, which is also maintained when operating conditions change and/or other process gases are used. This **and the knowledge of the heat profile** along the sensor, **make it possible to accurately predict the appropriate conversion factor.**

## WHY SETTLE FOR LESS?

The COMBI-FLOW control valve module is also unique. It is a fully modular design that is **adjusted** for optimum control behaviour **outside the base block.**

## HIGH TEMPERATURE PRESSURE CONTROL

A special 200°C version has been designed for pressure control applications with solid source.

## MALE/FEMALE INTERCONNECTION

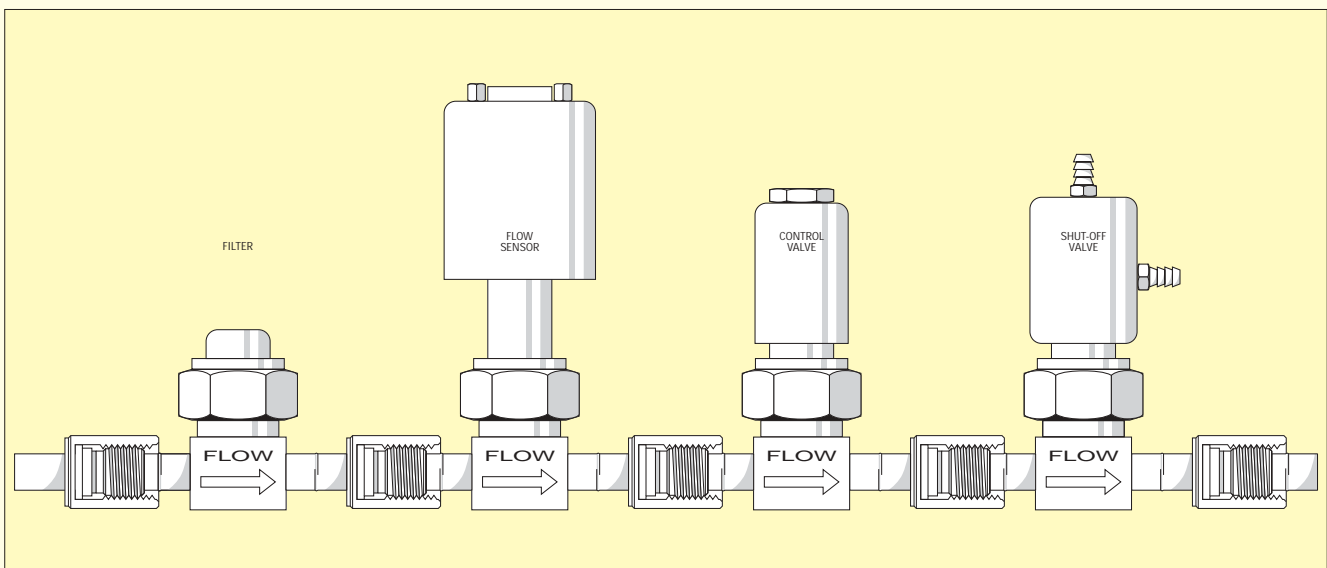

# FUNCTIONAL MODULES

## BASE-BLOCK

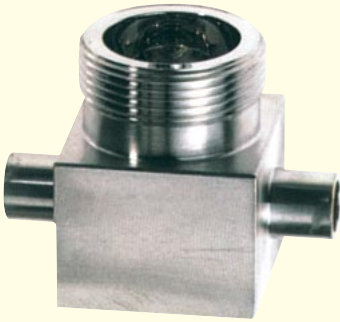

The functional modules are mounted on base-blocks. The base-blocks for the mass flow meter, the control valve, the pressure transducer and the filter modules are identical; for the shut-off valve and high-temperature valve they have a different internal cavity. There is only one (1) metal-to-metal seal of the well proven NUPRO design, with excellent resealing capability.

Virtually any desired combination of the available functions can be made by orbitally welding or coupling together the required numbers and types of base-blocks. When mounted in the line, the base-blocks have become an integral part of the system which need not be removed in case of service.

## PRESSURE TRANSDUCER

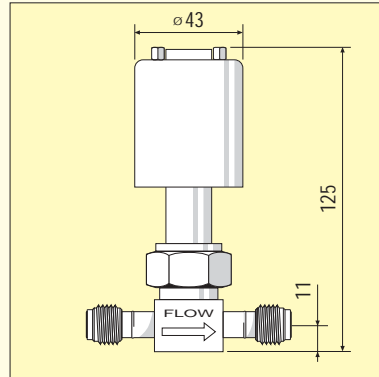

Piezo resistive pressure transducer with a stainless steel membrane.

## PRESSURE RANGES (ABSOLUTE OR GAUGE)

RANGE (BAR)	OVERLOAD (BAR)
0,3	2,5
0,5	4
1	7
2	7
5	30
10	30

## MASS FLOW METER

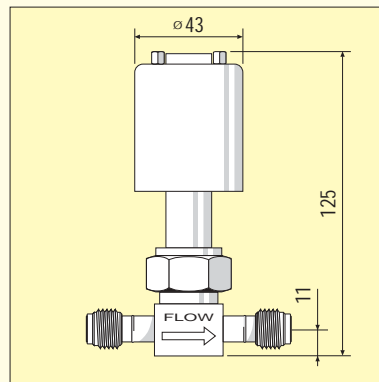

Thermal mass flow meter for ranges of 0,2..10 l<sub>n</sub>/min up to 1..50 l<sub>n</sub>/min air equivalent. The module for max. 100 l<sub>n</sub>/min is approx. 18 mm higher.

## PVDF FINEFILTER

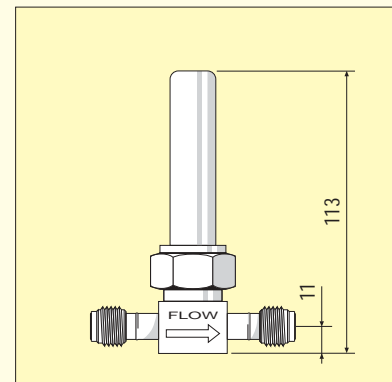

Ultraclean PVDF fine filter 0,05 micron.

## BASE-BLOCK

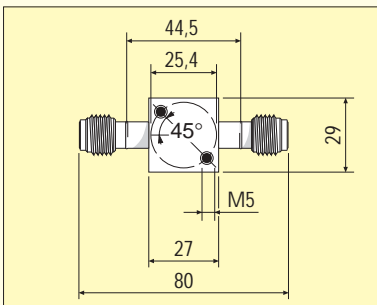

ALL DIMENSIONS IN MILLIMETRES

## PVDF FINE FILTER 0,05 MICRON

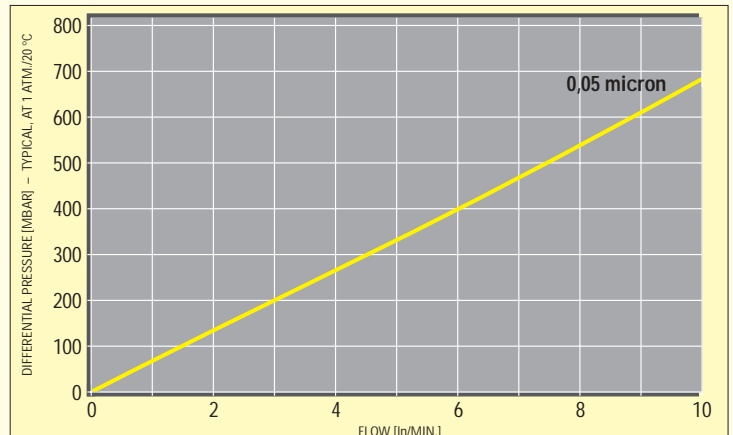

CONTROL VALVE (NC/NO)

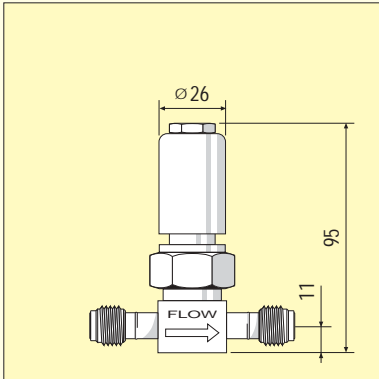

Normally closed or normally opened control valve for mass flow or pressure control with a max.  $K_v$ -value of  $4,9 \times 10^{-2}$  (max. operating temperature =  $70^\circ\text{C}$ ).

HIGH TEMPERATURE CONTROL VALVE

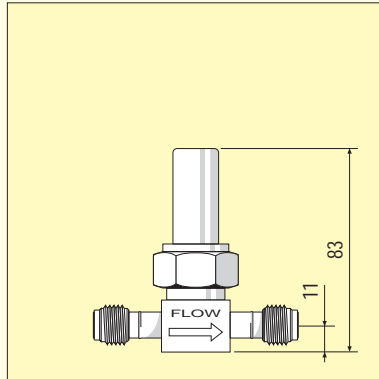

Normally opened control valve for high temperature pressure control. Maximum operating temperature  $200^\circ\text{C}$ . Maximum flow coefficient:  $K_v=1,7 \times 10^{-2}$ .

SINTERED METAL 316 L FILTER

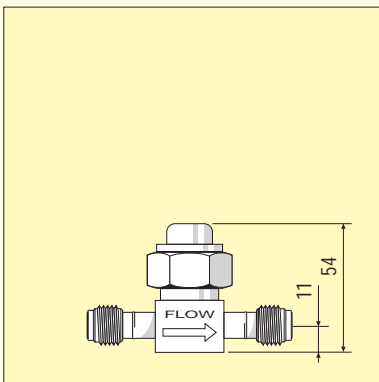

Porous sintered stainless steel filter in nominal pore sizes: 0,5 - 2 - 7 - 15 micron.

SHUT-OFF VALVE (NUPRO, NC/NO)

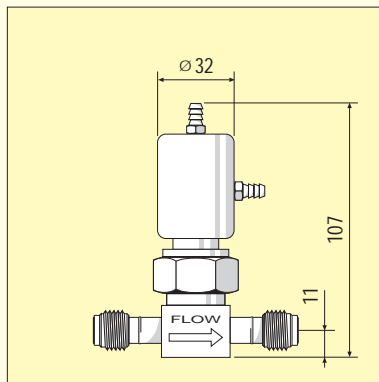

Normally closed or normally opened air actuated bellows shut-off valve (NUPRO).

FEATURES

- COMPACT AND FLEXIBLE DESIGN •
- ONE (1) METAL SEAL •
- ORBITAL WELDING •
- ELECTR. CHEMICALLY POLISHED •
- ULTRASONICALLY CLEANED •
- CLEANROOM ASSEMBLED AND INSPECTED •
- HELIUM LEAK TESTED •
- SERVICE FRIENDLY •

CHARACTERISTICS

STEM TIP:  
Kel-F  
FLOW COEFFICIENT:  
 $K_v=0.27$   
INBOARD HE LEAK TIGHTNESS:  
 $4 \times 10^{-9}$  mbar l/s  
AIR ACTUATOR PRESSURE:  
4 barg (NC)  
3 barg (NO)

POROUS SINTERED FILTER

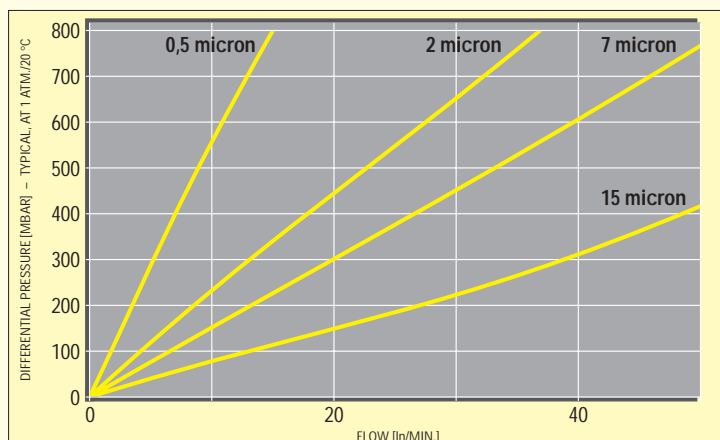

The COMBI-FLOW does not need multi-point linearisation, it is inherently linear; nor does it need a valve closure dependent auto-zero circuit, it is intrinsically stable.



Metal enclosure for RFI protection.

Sensor PC-board.  
Surface mount technology for best reliability.  
Temperature compensation.



Controller PC-board.  
Setting time as per SEMI guideline E17-91.

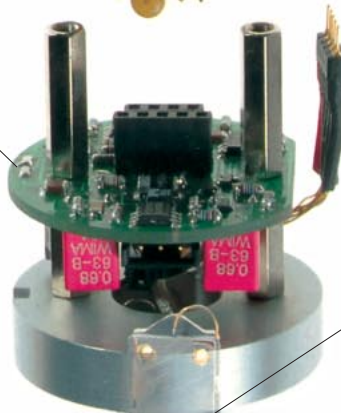

Patented sensor.  
Thin film technology.  
Fast 1st order response.  
Super stable.

Metal-to-metal seal.  
Resealing capability.

Hex nut for easy assembly.



Patented true laminar flow device, consisting of a stack of discs with etched flow channels for optimum linearity and predictable conversion factors for different gases.

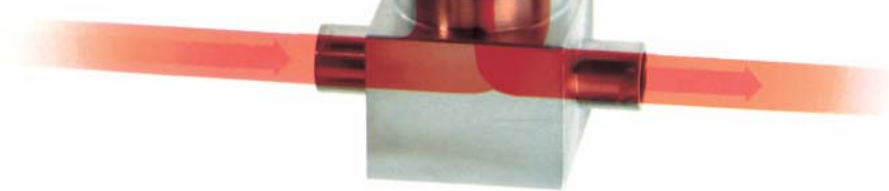





# SPECIFICATIONS

## PERFORMANCE

ACCURACY RATING	Standard calibration	± 1% FS at calibrated conditions, including non-linearity and repeatability.
	Polynomial calibration	± 0,5% of reading plus ± 0,1% FS.
SETTLING TIME	As per SEMI E17-91	1-2 seconds.
CONTROL STABILITY		± 0,1% fs typical 1 l <sub>n</sub> /min N2.
PRESSURE SENSITIVITY		0,1 %/bar typical N2. 0,01%/bar typical H2.
ATTITUDE SENSITIVITY		Max.error at 90° of horizontal 0,015% at 1 bar, typical N2.
VIBRATION SENSITIVITY		Virtually insensitive.
TEMPERATURE SENSITIVITY	As per SEMI E18-91	Off zero ~ 0,05% of FS/°C. Off span ~ 0,05% of reading/°C.
POWER SUPPLY SENSITIVITY		± 10% change in 15V -no effect.
FOLD-OVER SUPPRESSION		The output signal will not drop below max. flow signal till approx. 50 times the max. specified flow.
AUTO SHUT-OFF		Valve closes when setpoint drops below 1%.
LEAK INTEGRITY	As per SEMI E16-90	Each unit is tested to meet < 1 x 10 <sup>-9</sup> mbar.l.s <sup>-1</sup> He, additionally a pressure test at 1,5 times the max. stated operating pressure is performed.

## MECHANICAL CHARACTERISTICS

PROCESS CONNECTIONS		Std: 1/4" Face Seal or 1/4" OD compression type, orbitally welded to body. Other: on request.
MATERIAL OF CONSTRUCTION	Wetted	Stainless steel 316L or equivalent high alloy ferritic stainless steel.
OUTER SEAL		Only one metal-to-metal seal per module; excellent resealing capability.
VALVE SEAT	Plunger	Viton, EPDM, kalrez, elastomeric PTFE, or other on request.
WEIGHT		0,62 kg (Sensor + valve module).
SURFACE FINISH	Superclean	Ra 0,2..0,6 µm (5..15 micro inch) assembly, calibration, testing and packaging in clean room under Class 1000 conditions.



## OPERATING LIMITS

FLOW CAPACITY	Based on N2	Min. 10 ml <sub>n</sub> /min. Max. 100 l <sub>n</sub> /min. for control depending on K <sub>v</sub> -calculation.
CONTROL RANGE	Turn down	2..100%.
GASES		Any clean gas or gas mixture compatible with SS 316.
OPERATING TEMPERATURE	Ambient range	- 10°C to + 70°C.
MAXIMUM OPERATING PRESSURE		100 bar.
DIFFERENTIAL PRESSURE RANGE		50 mbar for low vapour pressure applications, up to 30 bar depending on K <sub>v</sub> -calculation.
MOUNTING POSITION		Any position, up to 10 bar. Contact factory when operating at higher pressures
WARM-UP TIME	After turning on power	20 min. for best accuracy. 2 min. for accuracy ± 2% FS.

## ELECTRICAL CHARACTERISTICS

POWER SUPPLY		+ 15Vdc, 300 mA max: – 300 mA for controller; – 35 mA for meter. - 15Vdc, 30 mA typical.
OUTPUT SIGNAL		0..5(10)Vdc linearly proportioned to mass flow; min. load impedance 2 k ohm at 5V; short circuit protected.
COMMAND SIGNAL		0..5(10)Vdc min. input impedance 1 M ohm.
REFERENCE SIGNAL OUTPUT		5(10)Vdc min. load impedance 2 k ohm.
VALVE PERFORMANCE		Monitor valve voltage by connecting a voltmeter to pin 4 (common) and pin 5 (valve +).
PURGE MODE		100% setpoint.
EMI/EFI		Completely shielded electronics.
ELECTRICAL CONNECTION		Male, 9-pin sub "D" connector.

## CALIBRATION

REFERENCES		Verified by NMI, the Dutch calibration organisation, and traceable to Dutch and international standards.
SYSTEM		Precision bore glass tubes with mercury sealed piston; automatic temperature and pressure compensation.
GASES		Each instrument is calibrated under the actual operating conditions whenever possible. A number of standard gases is available.
FLUID DATA		We have accumulated a data bank (FLUIDAT) that enables us to accurately determine the <b>gas properties</b> , such as density, specific heat and viscosity <b>under the prevailing operating conditions</b> . These are necessary to accurately calculate the (sliding) conversion factor by means of the FLUIDAT program, which is integrated in our calibration program.

# MODEL NUMBER IDENTIFICATION

A N | A N | A N

## FUNCTIONAL MODULES (IN FLOW DIRECTION)

F1	Flow meter, max. 50 l <sub>n</sub> /min
F2	Flow meter, max. 100 l <sub>n</sub> /min
P5	Pressure sensor
P6	Downstream pressure controller
P7	Upstream pressure controller
C0	Control valve, N.C.
C1	Control valve, N.O.
H1	High-temperature control valve
S0	Shut-off valve, N.C.
S1	Shut-off valve, N.O.
M0	PVDF fine filter
M1	Sintered metal filter

A | A | A — N N — A

## STYLE

H	Sensor
F	Controller, valve N.C.
G	Controller, valve N.O.

## OUTPUT

A	0-5 Vdc
B	0-10 Vdc

## SUPPLY VOLTAGE

C	+/- 15 Vdc
---	------------

## CONNECTIONS (IN/OUT)

0	None
1	1/8" OD compression type
2	1/4" OD compression type
3	6 mm OD compression type
7	1/4" Face Seal female
8	1/4" Face Seal male
9	Other

## SEALS (INTERNAL)

V	Viton
E	EPDM
P	PTFE Elastomere
Z	Other
0	None

## EXAMPLE



Hi-TEC MODEL M1F1C0 - FAC - 88 - V

## OTHER BRONKHORST HI-TEC PRODUCTS

In addition to the instruments of the COMBI-FLOW series described in this catalogue we would like to show some other product groups within our range of instruments.



### EL-PRESS

Pressure transducers and controllers for gases and liquids are built along the same lines as the EL-FLOW® instruments. The only difference is that there is no laminar flow device, and the flow sensor is replaced by a piezo-resistive pressure transducer. The measuring ranges are

between 2...100 mbar abs. or relative, and 8...400 bar. Upstream or downstream pressures up to 100 bar are controlled with integrally mounted control valves. For higher pressures separate control valves are used.



### EL-FLOW®

Mass flow meters and controllers for gases with an electronic housing suitable for laboratory conditions.

Instruments of the EL-FLOW® series are the only ones on the market that can control flow ranges between 0...1 ml<sub>n</sub>/min and 0...1250 l<sub>n</sub>/min between

vacuum and 400 bar in one range of instruments. This versatility in flow ranges and in operating conditions have made EL-FLOW® our best selling and field proven instrument series.



### LIQUI-FLOW®

Mass flow meters and controllers for liquids in ranges between 0,1...5 g/h and 0,4...20 kg/h (water equivalent). LIQUI-FLOW® flow meters only require a small differential pressure. In spite of measurement without a by-pass the rise in temperature of the fluid is minimal; only approx. 1...5 °C. This greatly limits the danger of evaporation or degradation of the fluid. For even smaller ranges Bronkhorst High-Tech offers the µ-Flow series; smallest range: 1,5...30 mg/h (water equivalent).



### CEM-SYSTEM

The CEM-System (Controlled Evaporation and Mixing) is an innovative Liquid Delivery System that can replace traditional Bubbler Systems. It consists of a liquid flow controller, an MFC for carrier gas and a temperature controlled mixing and evaporation device. The system is suitable for mixing liquid flows of 0,25-1000 g/h resulting in saturated vapour flows of 5 sccm to 20 slm.



### MULTI-BUS

Digital versions of EL-FLOW mass flow meters/controllers. The basic pc-board on the instrument contains all of the general functions needed for measurement and control. It has analog I/O-signals and also an RS-232 connection as a standard feature. In addition to this there is the possibility of integrating an

interface board with DeviceNet™, Profibus-DP® or FLOW-BUS protocol. Other product series like EL-PRESS, IN-FLOW, LOW-ΔP-FLOW and COMBI-FLOW can also be equipped with multi-bus digital pc-boards.



### CORI-FLOW®

For liquid flow ranges up to 600 kg/h Bronkhorst High-Tech designed a new series mass flow metering instruments, offering high accuracy (up to ±0,1% FS plus ±0,2% of Reading). CORI-FLOW®

utilises a patented, advanced Coriolis type mass flow sensor to achieve unsurpassed performance, even with changing operating conditions

in pressure, temperature, density, conductivity and viscosity. CORI-FLOW® is offered with or without integral control valve and analog and digital communication, RS-232 with Profibus-DP or Devicenet. The instruments can be applied for gases and liquids.

If one or more instruments described here are of interest to you, then please do not hesitate to contact your distributor.



Nijverheidsstraat 1a, 7261 AK Ruurlo, The Netherlands  
tel.: +31 573 458800, telefax: +31 573 458808

Internet: [www.bronkhorst.com](http://www.bronkhorst.com), e-mail: [sales@bronkhorst.com](mailto:sales@bronkhorst.com)

Distr.:

E.CFB.0503.D